

## **APPENDIX G**

---

### **EROSION AND SEDIMENT CONTROL PLAN**

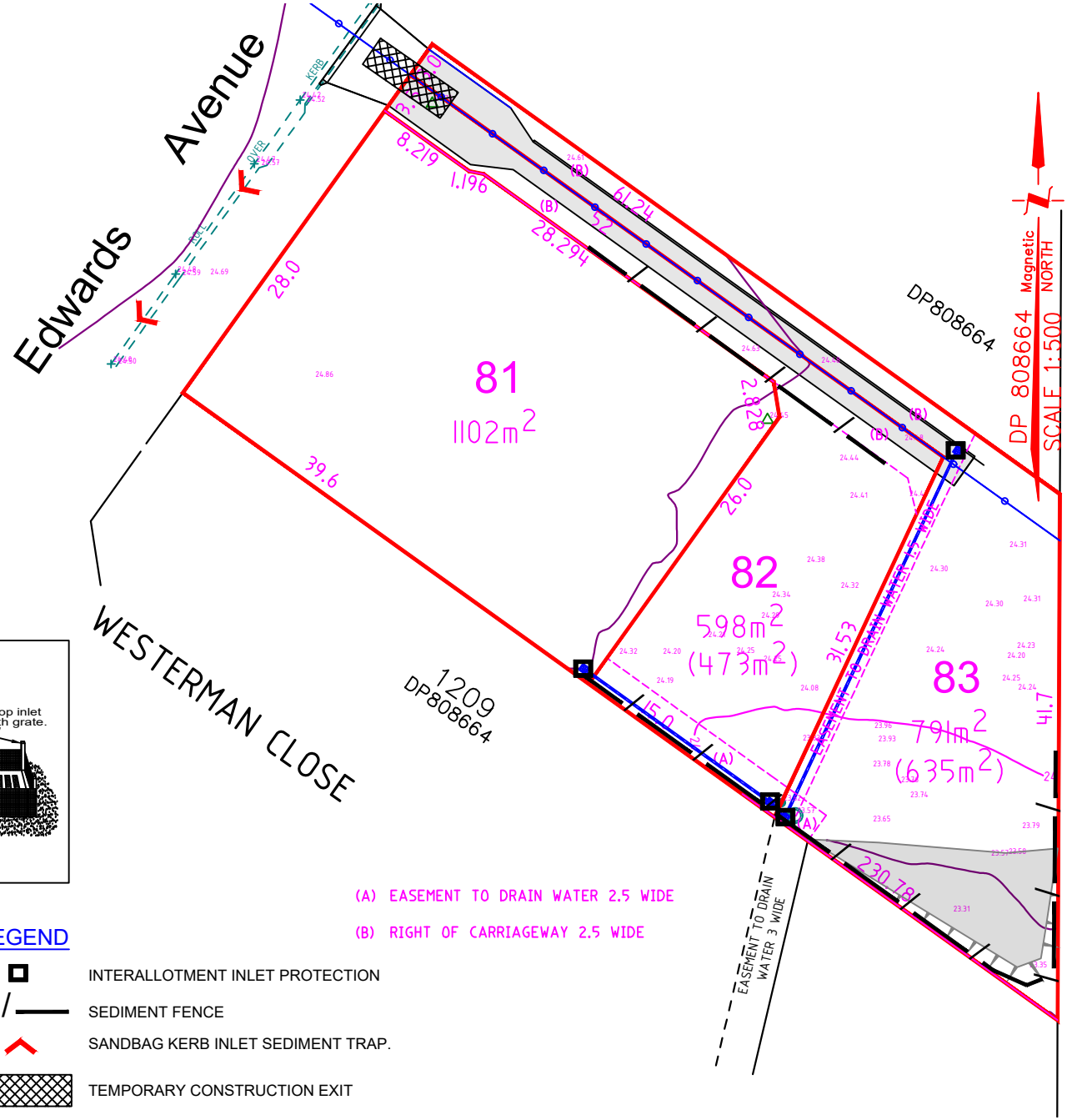
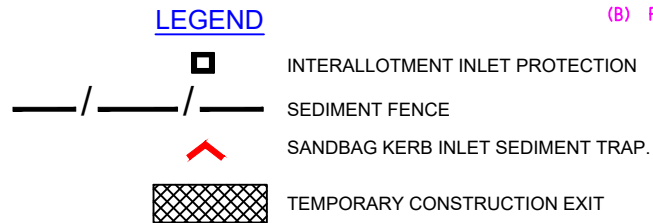
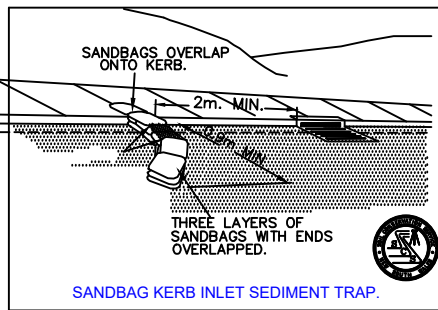
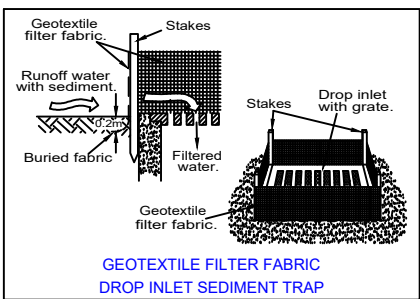
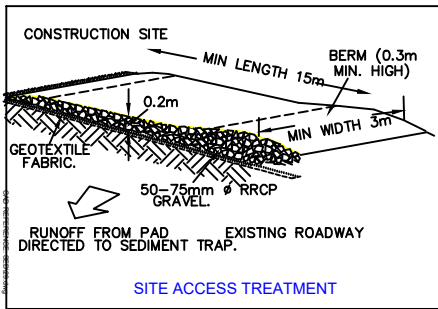
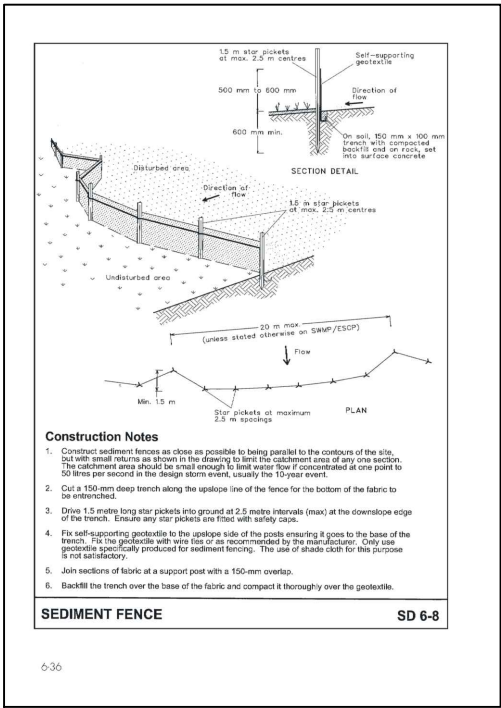

Revision A  
Date: 3/08/2021  
Job No. 21021

# Concept Erosion & Sediment Control Plan

## Lot 1208 DP 808664

### Edwards Avenue, Thornton